

## Features



- Constant current mode output with multiple levels selectable by dip switch
- Protections: Short Circuit/ Over load/ Over Current
- Full protection plastic housing easy installation
- IP20 design for indoor installation
- Cooling by free air convection
- Dimming function: Triac dimmable Phase cut dimmable
- Strong compatibility, flicker-free dimming

Model		ELED-50-C700/1400T						
Output	Rated Current	1400mA	1250mA	1200mA	1050mA	900mA	850mA	700mA
	Current Tolerance	±5%						
	DC Voltage	10-36V	10-40V	10-42V	10-48V	10-50V	10-50V	10-50V
	Rated Power	50.4W	50W	50.4W	50.4W	45W	42.5W	35W
	No-Load Voltage	52-60V						
Input	Voltage Range	180-240 VAC						
	Rated Frequency	47~63HZ						
	Power Factor	PF> 0.65/180VAC // PF>0.65/230VAC // PF>0.65/240VAC (Full loading)						
	Full Load Efficiency	80%	80%	80%	82%	82%	82%	82%
	AC Current	0.54A	0.53A	0.54A	0.53A	0.47A	0.44A	0.36A
	Leakage Current	<0.50mA						
Protection	Short Circuit	Hiccup mode, Recovers automatically after fault condition is removed						
	Over Load	≤120%						
	Protection	II						
Environment	Working TEMP	-40 ~ +60°C						
	Working Humidity	20~95%RH, non-condensing						
	Storage TEM Humidity	-40~+80°C, 10~95%RH						
	TEMP Coefficient	±0.03%/°C (0~50°C)						
	Vibration	10~500Hz, 5G 12min./ 1 cycle,period for 72 min. each along X,Y,Z axes						

<b>Safety &amp; EMC</b>	Safety standards	EN61347-1 EN61347-2-13	
	Withstand voltage	I/P-O/P:3.75KVAC	
	Isolation resistance	I/P-O/P : 100MΩ/500VDC/25°C/70%RH	
	EMC EMISSION	Compliance to EN55015,EN61000-3-2,3 (≥50%load)	
	EMC IMMUNITY	Compliance to EN61000-4,2,3,4,5,6,11,EN61547, A light industry level ( surge4KV)	
<b>Others</b>	Weight	0.32Kg	
	Size	178*61*24mm (L*W*H)	
	packing	290*215*140 (20PCS/CTN )	185*65*37 mm for inner box

## Mechanical Specification

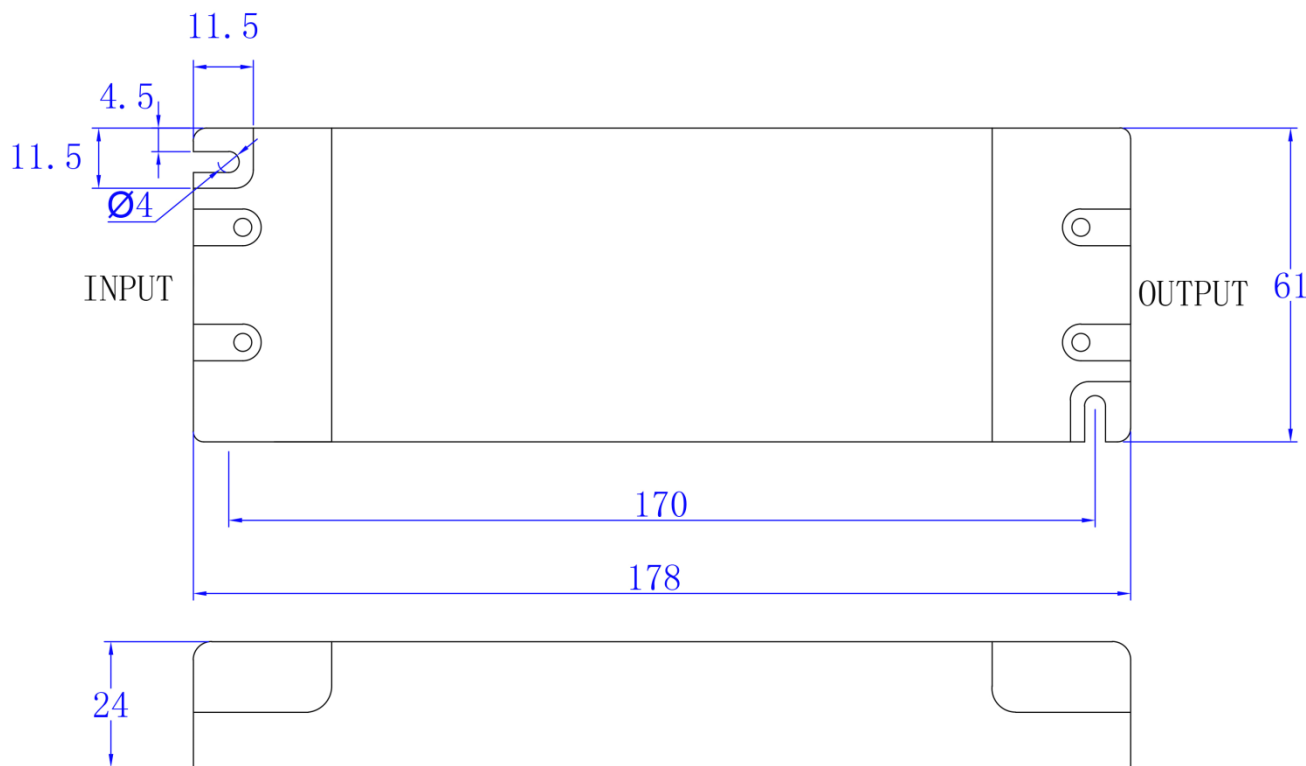

Connection Diagrams

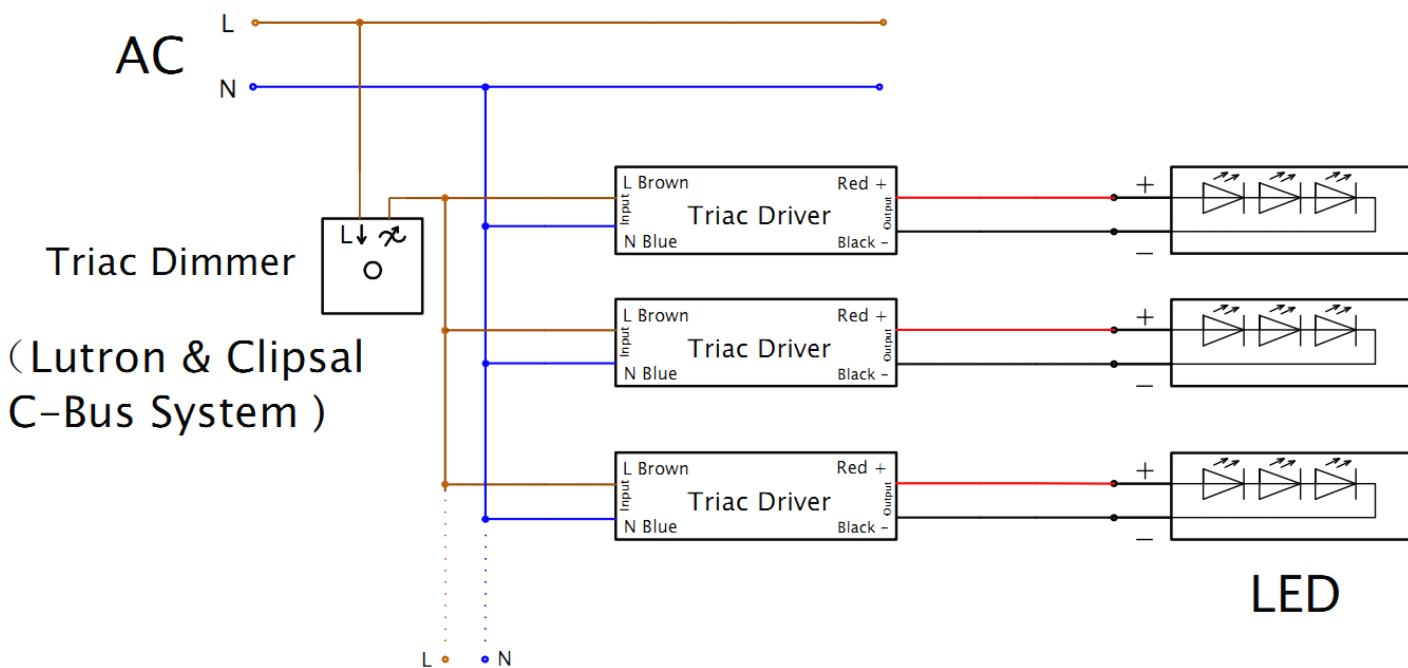
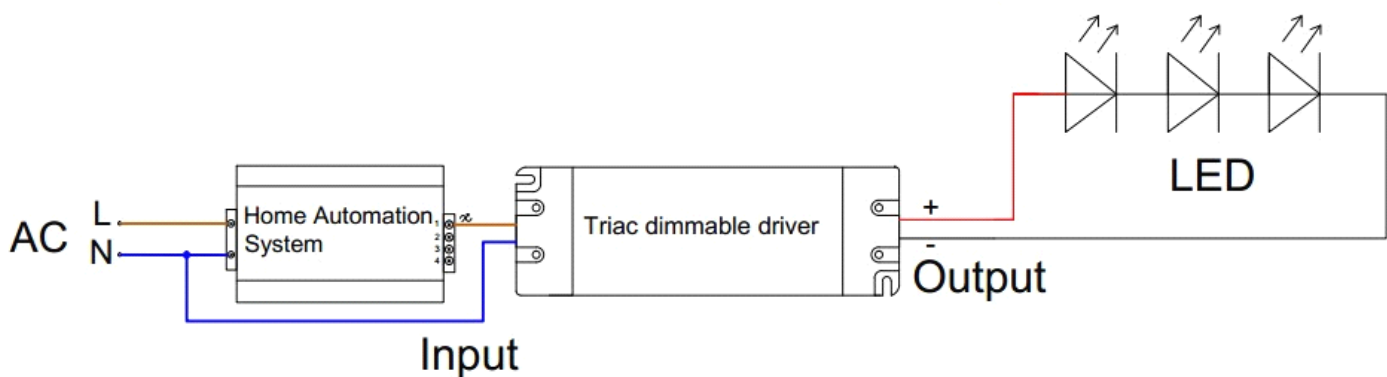
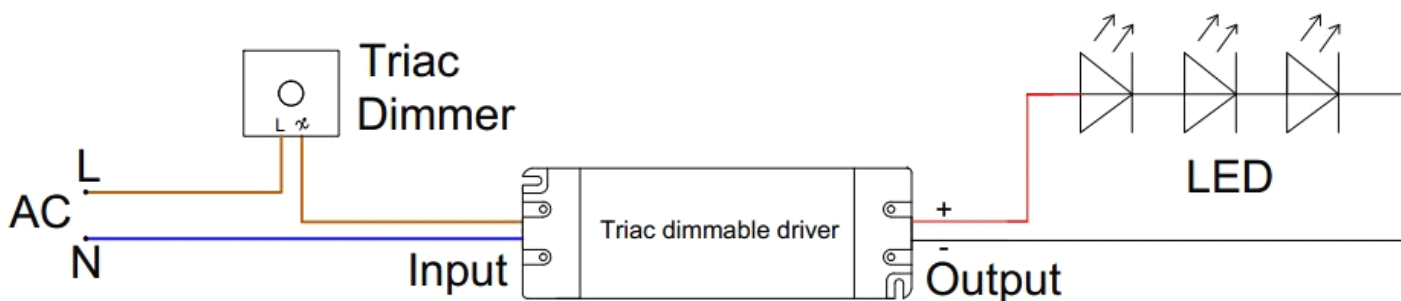

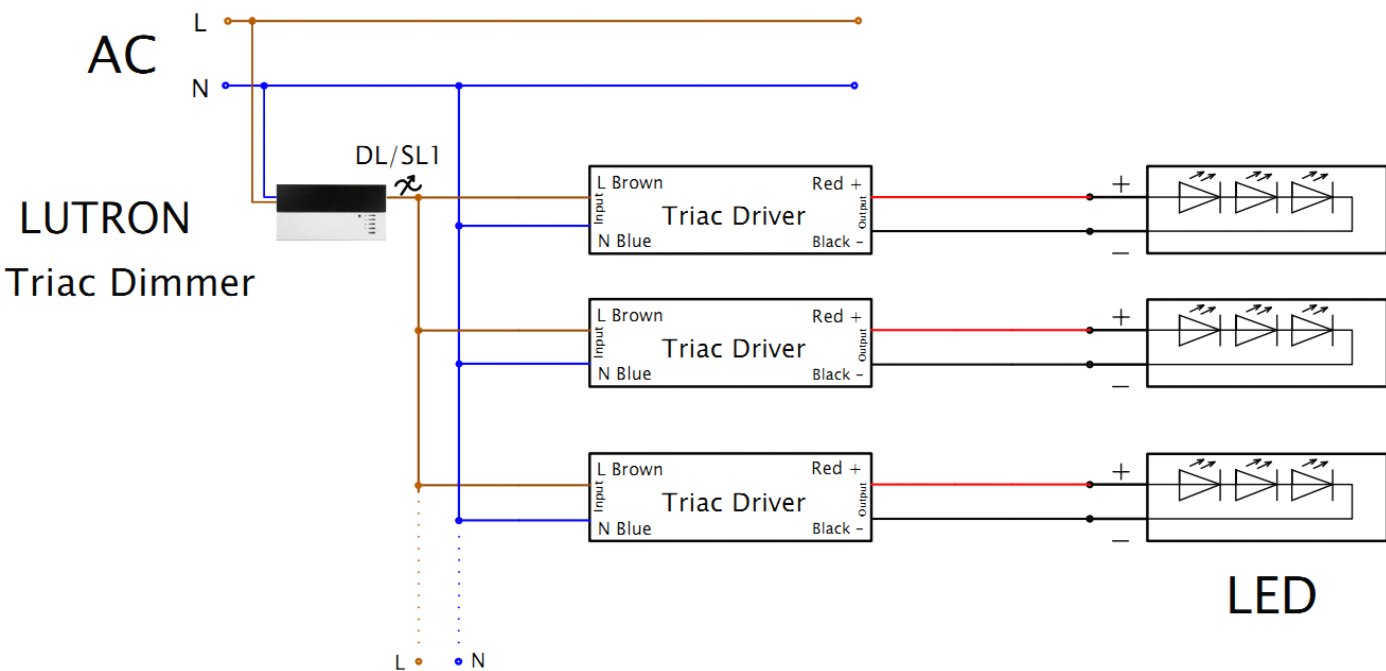

**Derating Curve**

